



Your Outdoor Cinema Specialist

Inflatable screens, projectors, speakers & complete outdoor cinema solutions.

PRODUCT GUIDE (INCLUDES PRICING)

Division : Outdoor Movie Screen Sales

Screen range : Backyard | Event | Professional



Contents

| | |
|-------------------------------|----|
| Introduction | 4 |
| Product Features | 6 |
| Size Overview & Pricing | 8 |
| Terms & Conditions | 12 |
| Contact Details | 14 |

An outdoor cinema setup on a grassy lawn. In the background, a large, dark inflatable screen stands on a grassy area. In the foreground and middle ground, several wooden lounge chairs with light-colored cushions are arranged in rows. Small wooden tables are placed between the chairs, some holding baskets. A large, light-colored blanket or rug is spread out on the grass in the lower right foreground. The background is filled with palm trees and other tropical foliage. The entire scene is dimly lit, suggesting dusk or dawn.

INTRODUCTION

Own Your Own Outdoor Cinema Experience

Bring movie night to life with Scenima's premium inflatable movie screens, designed for unforgettable indoor and outdoor cinema experiences.

Whether you're creating a backyard cinema, hosting school or community events, or launching a commercial outdoor movie business, our screens are built for durability, easy setup, and exceptional viewing quality.

Backyard Series: Ideal for families, private movie nights and small gatherings.

Event Series: Perfect for schools, churches and community screenings.

Professional Series: Designed for large-scale events, drive-ins, resorts, and commercial operators, featuring an elevated design for enhanced visibility.

No matter the audience size, Scenima has a screen to help you create unforgettable movie experiences under the stars.

Why Choose Scenima Screens?

- High-quality inflatable cinema screens
- Front & rear projection compatible
- Portable and easy to set up
- Quiet external blower system included
- Durable PVC projection surface
- 12-month warranty included



PRODUCT FEATURES

PRODUCT FEATURES



STRONG STABILITY

The inflatable movie screen adopts the design of a tripod, which is more supportive. Even if you don't use the rope, it won't tilt. When used with a rope, it will be stronger and will not tilt when the wind blows.



EASY TO CARRY

The screen is light weight and comes with a convenient storage bag that allows you to carry your inflatable movie screen wherever you want.



EASY TO REASSEMBLE & DETACH

The white projection screen is detachable with magic tape, easier to reassemble & detach. If the surface gets dirty take it off and wash it.



EXTERNAL BLOWER

Each screen comes with a quiet, high-power (250/550w) electric blower. The blower is silent so the sound will not be heard once the movie starts, it is also an external blower, which is more convenient.

NOTE: The blower needs to be left on to maintain inflation.



QUICK INFLATION

The blower inflates the screen in 2-10 minutes. We recommend putting the blower behind the screen.



ULTRA WIDE VIEWING ANGLE

No need to sit directly in front of the screen, just choose the most comfortable viewing position to enjoy the movie night.

An outdoor movie screening at night. A large crowd of people is sitting on the grass, watching a movie on a large screen. The screen shows a scene with two people. The text "SIZE OVERVIEW & PRICING" is overlaid on the screen.

SIZE OVERVIEW & PRICING

BACKYARD SERIES

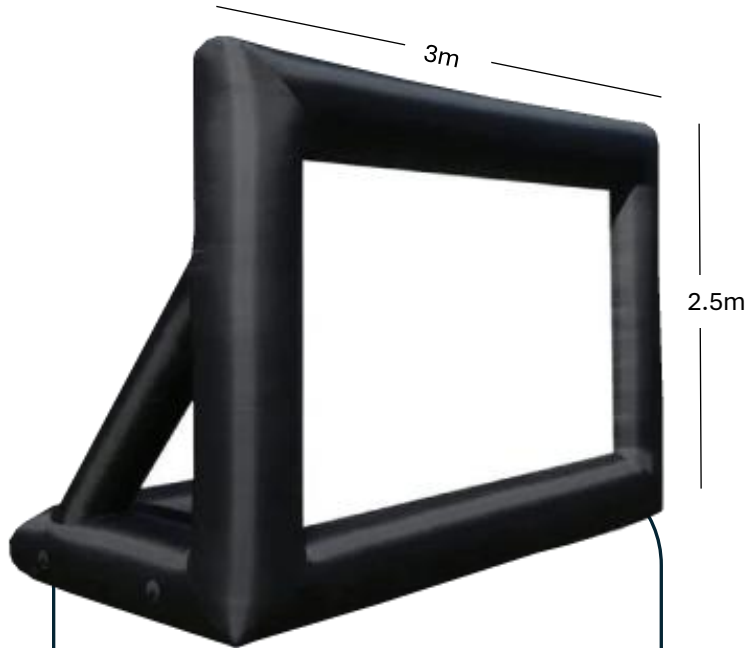

BACKYARD 1

For up to 20 people

Screen size: 3m x 2.5m

Front or rear projection screen

Handheld blower(250W)

Ropes & floor pegs

12 Month warranty

Manual

R 18 500

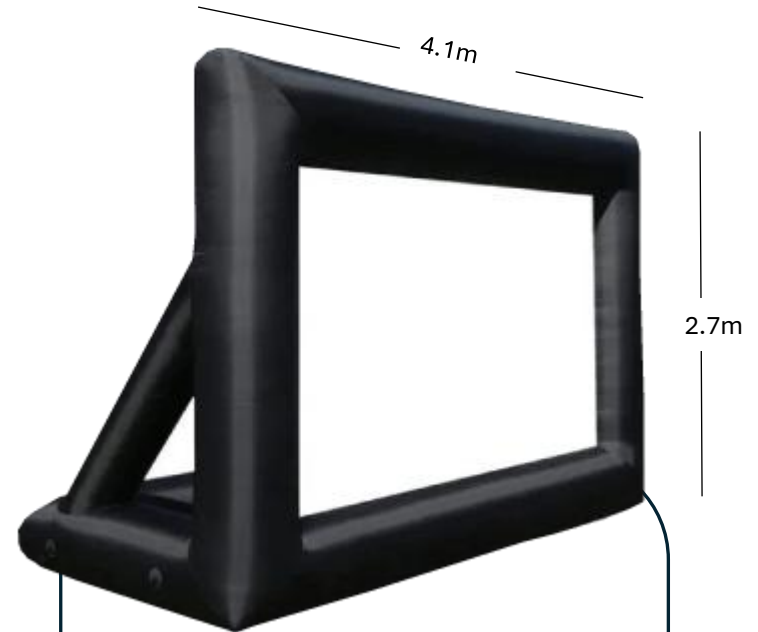

BACKYARD 2

For up to 50 people

Screen size: 4.1m x 2.7m

Front or rear projection screen

Handheld blower(250W)

Ropes & floor pegs

12 Month warranty

Manual

R 20 500

EVENT SERIES

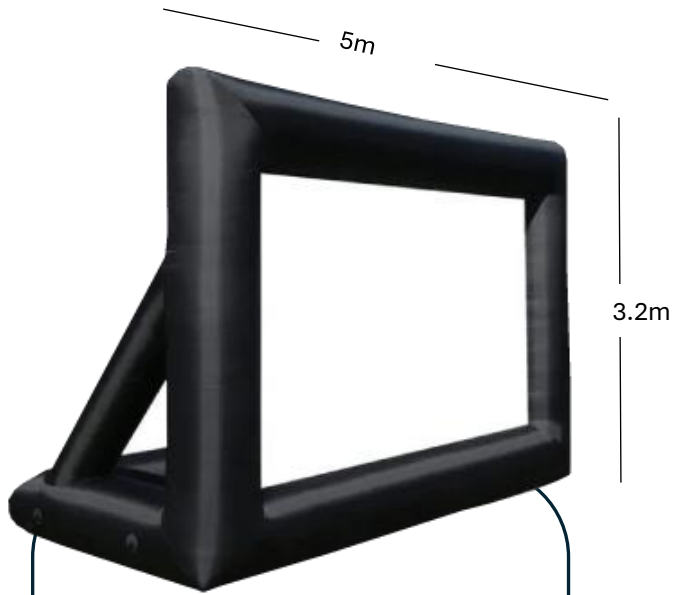

EVENT 1

For up to 120 people

Screen size: 5m x 3.2m
Front or rear projection screen
Handheld blower(250W)
Ropes & floor pegs
12 Month warranty
Manual

R 24 800



EVENT 2

For up to 250 people

Screen size: 6.7m x 4m
Front or rear projection screen
Handheld blower(250W)
Ropes & floor pegs
12 Month warranty
Manual

R 27 800

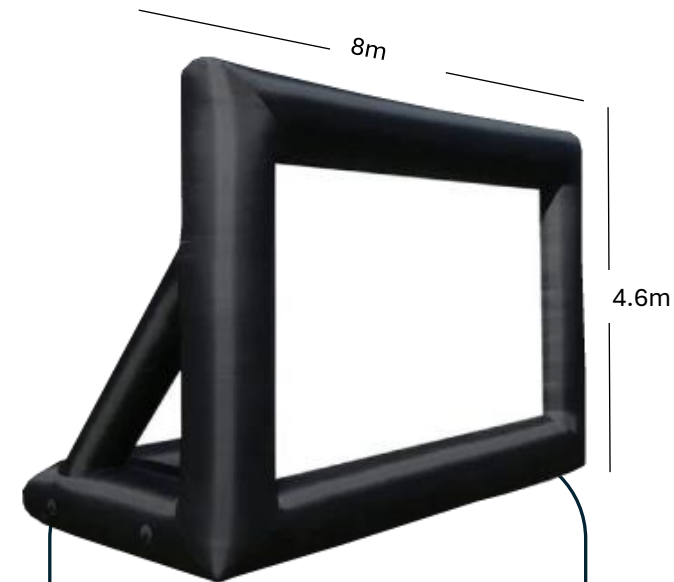

EVENT 3

For up to 300 people

Screen size: 8m x 4.6m
Front or rear projection screen
Handheld blower(250W)
Ropes & floor pegs
12 Month warranty
Manual

R 30 800

PROFESSIONAL SERIES



PROFESSIONAL 1
For up to 400 people

Screen size: 8m x 5.4m
Front or rear projection screen
Handheld blower(550W)
Ropes & floor pegs
12 Month warranty
Manual

R 34 800



PROFESSIONAL 2
For up to 500 people

Screen size: 9m x 6m
Front or rear projection screen
Handheld blower(550W)
Ropes & floor pegs
12 Month warranty
Manual

R 37 800



PROFESSIONAL 3
For up to 750 people

Screen size: 10m x 7m
Front or rear projection screen
Handheld blower(750W)
Ropes & floor pegs
12 Month warranty
Manual

R 48 800

A person wearing a dark t-shirt with the text "MOVIE NIGHT OUTSIDE" and "AUCTION" is leaning over a table, working on a computer setup. The setup includes a monitor, keyboard, and mouse. The person is wearing a dark cap and is positioned outdoors near a body of water. In the background, there are several blue chairs on a raised platform and a blue boat. The scene is dimly lit, suggesting dusk or dawn. The text "TERMS & CONDITIONS" is overlaid in white on the image.

TERMS & CONDITIONS

Lead Time

Standard lead time for orders is 14-20 business days from confirmation of deposit payment.

Lead times are estimates and may vary due to manufacturing schedules, customs clearance, courier delays, public holidays, or other factors beyond Scenima's control.

Inspection on Delivery

Customers are required to inspect all products within 7 calendar days of delivery or collection.

Any manufacturing defects, missing items, or damage believed to have occurred prior to delivery must be reported to Scenima in writing, together with supporting photographs, within this 7-day period.

Failure to report defects within 7 days will be deemed acceptance of the product in good condition.

Warranty

All screens include a 12-month manufacturer's warranty covering defects in materials and workmanship under normal use.

The warranty does not cover:

- Accidental damage
- Incorrect setup or operation
- Wind, storm, rain, or weather-related damage
- Punctures, tears, abrasions, or burns
- Improper storage or transport
- Damage caused by modifications, repairs, or alterations performed by anyone other than Scenima or an authorised repairer

Warranty claims may require photographic evidence and inspection of the product.

Returns & Exchanges

As screens are imported and supplied to order, no refunds, returns, or exchanges will be accepted once production, procurement, or shipping has commenced.

Products may only be returned where a verified manufacturing defect exists and Scenima has been provided a reasonable opportunity to inspect and assess the claim.

Payment Terms

A 50% non-refundable deposit is required to confirm an order.

The remaining balance must be paid in full at least 24 hours prior to dispatch.

No products will be released, shipped, or handed over until full payment has been received and cleared.

Delivery

Delivery is arranged through third-party courier services and may be subject to additional charges depending on the delivery location.

Risk in the goods passes to the customer upon delivery to the specified address.

Scenima cannot be held liable for delays, loss or damage occurring after the goods have been handed to the courier, although we will assist in facilitating claims where possible.

Care & Operating Instructions

To maximise product lifespan:

- Do not use the screen in strong winds, storms or rainy conditions.
- Ensure the screen is securely anchored at all times during use.
- Store the screen indoors in a clean, dry environment.
- Do not drag the screen across rough surfaces.
- Use only the supplied blower or a blower of equivalent specification.
- Failure to follow these instructions may void the warranty.

[Click here](#) to download our inflatable screen set-up manual.

Limitation of Liability

Scenima's liability shall be limited to the repair or replacement of defective products where a valid warranty claim exists.

Under no circumstances shall Scenima be liable for indirect, consequential, incidental, or economic losses arising from the use, misuse, failure, or inability to use the product.

The customer assumes full responsibility for the safe installation, operation, and supervision of the equipment once delivered.

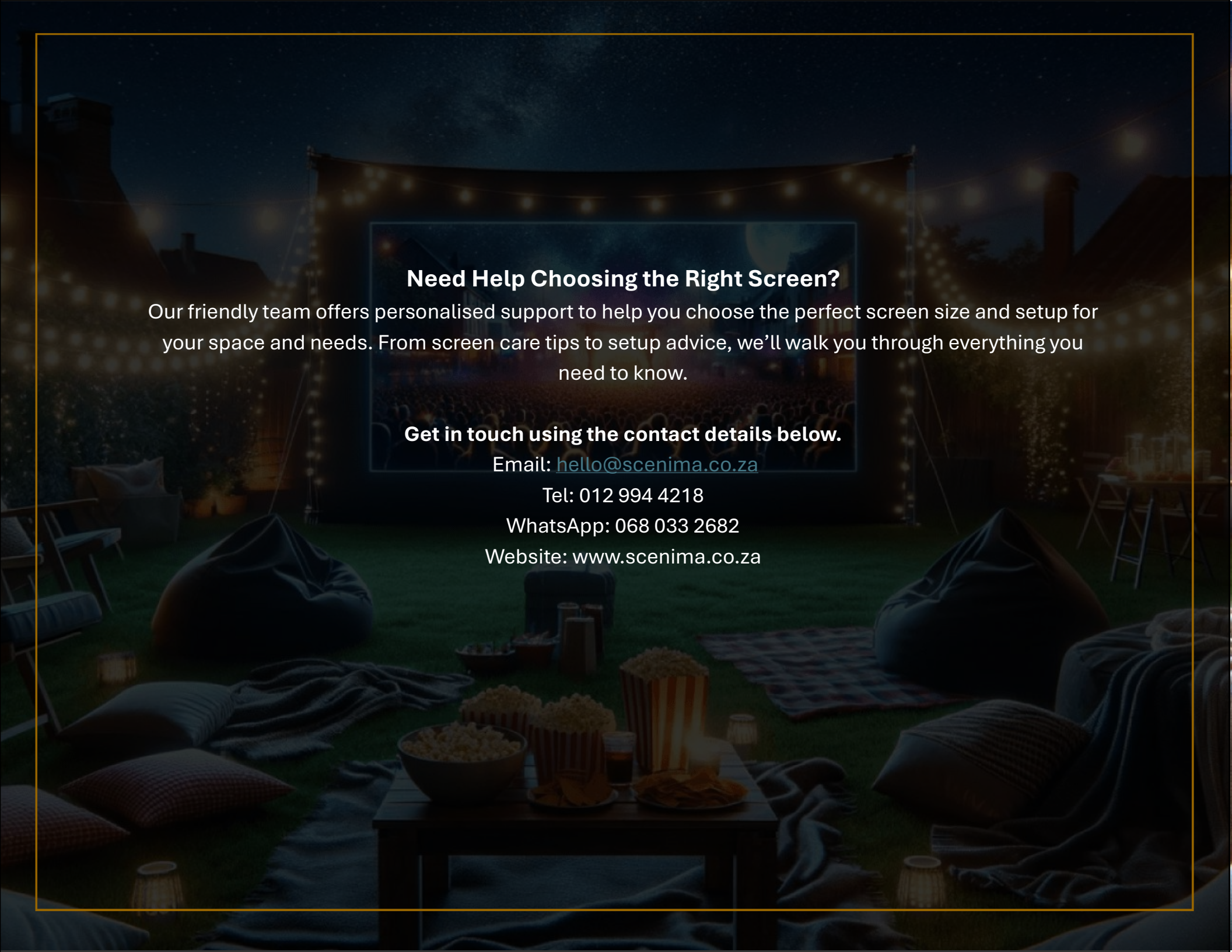
A night scene of an outdoor cinema setup. A large screen is suspended in the background, displaying a crowd of people. The foreground is filled with beanbag chairs, blankets, and a table with popcorn and drinks. The scene is illuminated by warm string lights and lanterns, creating a cozy atmosphere.

Need Help Choosing the Right Screen?

Our friendly team offers personalised support to help you choose the perfect screen size and setup for your space and needs. From screen care tips to setup advice, we'll walk you through everything you need to know.

Get in touch using the contact details below.

Email: hello@scenima.co.za

Tel: 012 994 4218

WhatsApp: 068 033 2682

Website: www.scenima.co.za